

SONDHEIM

on



PHOTO BY JOAN MARCUS

Music and lyrics by
**Stephen
Sondheim**

*Conceived and directed
on Broadway by*
James Lapine

Directed by Curtis J. Williams
Music Direction by Julian Bryson

JUNE 5-21, 2026



SEASON 106

5th PRODUCTION



VyStar Credit Union proudly supports

Theatre Jacksonville's
Sondheim on Sondheim

FEDERALLY
INSURED
BY **NCUA**



Do Good. Bank Better.™

SONDHEIM

on

Music and lyrics by
**Stephen
Sondheim**

Conceived and
directed on
Broadway by
James Lapine

Directed by **Curtis J. Williams**
Music Direction by **Julian Bryson**



CAST

Emily Charleton
Leanne Gullo
Julia Fallon Johns
Morgan Perry
Daniel Pesante
Alyssa Stark
Josh Waller
Tevin Washington
Jon Woodbine

There will be one 15-minute intermission.

*SONDHEIM ON SONDHEIM is presented through special arrangement with
Music Theatre International (MTI).*

*All authorized performance materials are also supplied by MTI.
www.mtishows.com*

Originally produced on Broadway by the **Roundabout Theatre Company.**

THE VIDEOTAPING OR MAKING OF ELECTRONIC OR OTHER AUDIO AND/OR VISUAL RECORDINGS OF THIS PRODUCTION OR DISTRIBUTING RECORDINGS ON ANY MEDIUM, INCLUDING THE INTERNET, IS STRICTLY PROHIBITED, A VIOLATION OF THE AUTHOR'S RIGHTS, AND ACTIONABLE UNDER UNITED STATES COPYRIGHT LAW.

SPECIAL THANKS

Peterbrooke Chocolatiers,
Minuteman Press-Downtown Jacksonville, Movalo

Online at **www.theatrejax.com**

A THRIVING CREATIVE ECONOMY ENHANCES THE QUALITY OF LIFE FOR US ALL. SUPPORTED IN PART BY FLORIDA ARTS & CULTURE AND THE MERIT-BASED CULTURAL SERVICE GRANT PROGRAM, ADMINISTERED BY THE CULTURAL COUNCIL OF GREATER JACKSONVILLE WITH FUNDING FROM THE CITY OF JACKSONVILLE AND OUR ELECTED OFFICIALS, WE EXTEND OUR GRATITUDE TO ALL PARTNERS WHO MAKE THIS POSSIBLE.



Our Deepest Gratitude to all our supporters!

*In honor and appreciation
of the role our treasured
patrons have played
for over 100 years,
Theatre Jacksonville has
established giving levels
beginning at only \$50.*

\$10,000+

The City of Jacksonville

The Cultural Council of
Greater Jacksonville

The Delores Barr
Weaver Forever Fund,
Est. 2015

The Dubow Family
Foundation

The Elizabeth Brown
Foundation

Florida Department
of State, Division of
Cultural Affairs

The Jessie Ball duPont
Fund

John D. Baker III

Nancy Chartrand
Advised Fund

The Harold K. Smith
Playhouse Endowment

Michael Ward &
Jennifer Glock
Foundation

The Weaver Family
Foundation

In Memory of
Brad Trowbridge

**Our Deepest
Gratitude**
to all our supporters!

\$5,000-\$9,999

Anonymous

Eleanor & Kendall
Bryan

Delegal Poindexter &
Underkofler P.A.

The Iracki Family

The Staudt-Killea
Family

The Thomas M. Kirbo
& Irene B Kirbo Trust

VyStar Credit Union

\$1,000-\$4,999

Anonymous

Glenda Anthony

Janice & David Antico

Betsy & Stephen Crosby

Pat & Norm Foy

Greg Hewitt

Andrew Howe
Scholarship Fund

Matt King

The Leach Family

Jennifer Mansfield

Underwood Jewelers
Corporation

Stephen Shewbrooks

Mark Hayes &
Cynthia Swank

Verna Urbanski

DIRECTOR'S LETTER

The first time I heard a song by Stephen Sondheim, I didn't even realize it was his work. I only remember being deeply invested in what would happen to Tony and Maria. "Tonight, tonight, it all began tonight. I saw you, and the world went away." That is the beauty of Sondheim's music: the words capture emotional vulnerability and take it on a rollercoaster ride.

Sondheim on Sondheim is a rare show that allows the audience to see behind the costumes, behind the sets, behind the spectacle. It is a show about music. Its true rarity lies in learning how, and sometimes why, these songs were written by Sondheim himself. As an audience, we are given a glimpse into the inner workings of the mind of a musical genius. Sometimes it is cluttered, sometimes it is messy, but it is always honest.

Directing this show has been equally complex and enjoyable. It is a show that will make you laugh, make you cry, and make you think. It is a testament to the true power of music. Sondheim takes that power a step further through his ability to express a myriad of emotions, ideas, and lessons within each bar of music on the page. He reminds us that the human condition is universal and not always easy, but surrounding ourselves with the people we love can help us along our journey.

— Curtis J. Williams

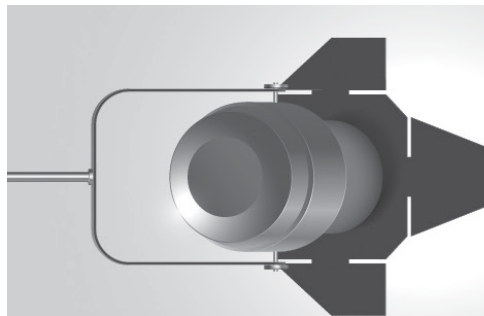

**EXPLORE!
EXPAND!
ENTERTAIN!**

MUSICAL NUMBERS

ACT ONE

OVERTURE

I'LL MEET YOU AT THE DONUT

INVOCATION/FORGET WAR

LOVE IS IN THE AIR

COMEDY TONIGHT

TAKE ME TO THE WORLD

SO MANY PEOPLE

SOMETHING'S COMING

YOU COULD DRIVE A PERSON CRAZY

THE WEDDING IS OFF

NOW YOU KNOW

FRANKLIN SHEPARD, INC.

GOOD THING GOING

WAITING FOR THE GIRLS UPSTAIRS

EPIPHANY

LOVING YOU

HAPPINESS

EVER AFTER

A WEEKEND IN THE COUNTRY

SUNDAY

ACT TWO

GOD

LOSING MY MIND/NOT A DAY GOES BY

OPENING DOORS

THE BEST THING THAT EVER HAS

HAPPENED

MULTITUDES OF AMYS

HAPPILY EVER AFTER

BEING ALIVE

AH, BUT UNDERNEATH

IN BUDDY'S EYES

SOMETHING JUST BROKE

GUN SONG

DO I HEAR A WALTZ

SMILE, GIRLS

FINISHING THE HAT

BEAUTIFUL

CHILDREN WILL LISTEN

SEND IN THE CLOWNS

COMPANY/OLD FRIENDS

ANYONE CAN WHISTLE

Theatre
for Babies

Theatre *for*
Explorers

Theatre
for Kids

JUNIOR
Mainstage

Summer
CAMP

THEATRE *for*
grown-ups

COACHING
for INDIVIDUALS

Learn more online at theatrejax.com/education

Our Deepest Gratitude to all our supporters!

\$250-\$999

Anonymous

Nancy & Kevin Bodge

Davron Cardenas

Cathryn Finke

David Gile

Mike Goldman

Leah Goryl

Holly & Redgie Gutshall

The Habermehl Family

Melody & T.R. Hainline

Boyce & Johnson
Family

Margaret Barton &
Tom Kimbrough

Kristen & Tom
Majdanics

Janice & C. David
Martin

Rosemary McCorkle

Linda & Ken McEneyr

Denise & Robert
Meissner

Sandra Myers

Farah Nesargi

Mildred Gloria Pepe

Laura Jane & Buck
Pittman

COMPANY BIOS

EMILY CHARLETON studied musical theatre at NYU's Steinhardt School. She is a Navy Brat, a Navy Veteran, and a Navy Spouse. She spent eight years in the U.S. Navy fleet bands as a vocalist. Recent roles include Berthe in *Pippin* (Theatre Jacksonville), Miss Shingle in *A Gentleman's Guide to Love and Murder* (OPCT), and Penelope Pennywise in *Urinetown* (5 & Dime). She and her husband, Ian, have traveled the world thanks to the U.S. Navy and have been living in Jacksonville since 2023.

LEANNE GULLO is honored to have the opportunity to perform alongside so many talented artists on this stage. She was last seen on the Theatre Jacksonville stage in their recent production of *Pippin* as Fastrada. Leanne has appeared on stage all over the Jacksonville area. Some favorite roles include Mother Superior (*Sister Act*, PBTS), Tammy (*Escape to Margaritaville*, ABET), and Eva Kavanova (*Traces in the Wind*, TJ). During the day, Leanne is a K-2 Music Teacher at Yulee Primary School in Yulee, FL.

JULIA FALLON JOHNS is elated to return to the Theatre Jacksonville stage. You may remember her from previous performances such as *Beehive!*, *Something Rotten!*, and *Into The Woods*. Julia has loved Stephen Sondheim's music as long as she can remember and is proud to be a member of this cast. Other recent performances include *Batboy!* (ABET), *Urinetown* (The 5 & Dime) and *Much Ado About Nothing* (Perused By A Bear Shakespeare). Julia would like to thank Curtis, Julian and the entire team as well as her family, friends, and especially her son Jude for supporting her dream to perform.

MORGAN PERRY is so excited to be performing again with Theatre Jacksonville in *Sondheim on Sondheim!* She was most recently seen onstage with Theatre Jax as Philia in *A Funny Thing Happened on the Way to the Forum*, and Sister Mary Jo in *Desperate Measures*. Other favorite roles include Belle (*Beauty and the Beast*), Maria (*The Sound of Music*), Portia (*Something Rotten!*), and Anytime Annie (*42nd Street*). Offstage, Morgan is a nurse practitioner at Well&You, and dog mom to Bella. Many thanks to her family and friends for always supporting her theater endeavors!

DANIEL PESANTE is thrilled to return to Theatre Jacksonville for *Sondheim on Sondheim*. He was last seen at Theatre Jacksonville in Sarah Boone's *Mom Before Dad*. A Douglas Anderson alumnus and Jacksonville University vocal performance graduate, his recent credits include *Godspell*, *Much Ado About Nothing*, and starring as Guido Contini in *Nine*. He has performed extensively across the Jacksonville area for over a decade and formerly served as director of the Big Orange Chorus. He is incredibly grateful to celebrate Sondheim's legacy with this wonderful cast.

ALYSSA STARK is excited to perform in her first show with Theatre Jacksonville for *Sondheim on Sondheim!* She's always had a passion for music since she was a child, and thought of choir as her home away from home growing up. She graduated last year from Jacksonville University with her bachelor's degree in music performance, and a minor in Women and Gender Studies. She has enjoyed her roles in *The Magic Flute*, *Madama Butterfly*, *Elijah*, *Well Behaved Women*, *Mary Poppins*, *Macbeth*, and various shows attributed to different composers. When she's not practicing or on the stage, she can be found reading mythology, preparing for her master's degree, or spending time with her family. Alyssa would like to thank her family, friends, and teachers for their continued support in her journey, and she hopes you enjoy the show!

JOSH WALLER's history with Stephen Sondheim goes all the way back to his very first musical: Tony in *West Side Story* his senior year of high school. Since then, he's had the amazing honor of performing in many of Sondheim's shows, namely Pseudolus in *A Funny Thing Happened...* (Jacksonville University), Anthony in *Sweeney Todd* (Players by the Sea), Charley in *Merrily We Roll Along* (ABET), Bobby in *Company* (The 5 & Dime), Guitau in *Assassins* (The 5 & Dime), and as Marcus Lycus in *A Funny Thing Happened...* last year with Theatre Jacksonville and the Florida Theatre. Josh is a familiar face on the Theatre Jax stage, starring as Nick Bottom in *Something Rotten!*, Jean Valjean in *Les Misérables*, Jean François Millet in *Is He Dead?*, and Archibald Craven in *The Secret Garden*, among many others. Some of his other favorite local credits include Marvin in *Falsettos* (The 5 & Dime), Burrs in *The Wild Party* (PBTS), Bruce in *Fun Home* (Limelight Theatre), Leo Frank in *Parade* (PBTS), and Hedwig in *Hedwig and the Angry Inch* (The 5 & Dime).

TEVIN WASHINGTON is overjoyed to be back on the Theatre Jacksonville stage this season. This time, to perform musical works composed by the industry titan that was Stephen Sondheim! His introduction to the genre of "musical theatre" was in high school. During that time, he performed "Sunday" with another small vocal ensemble right here at Theatre Jacksonville (weird, right!?) That has remained one of his favorite musical numbers to date. After stepping into theatre performance just last year, his musical credits so far include *Oliver!*, *Meet Me in St. Louis*, and *Oklahoma* (A.C.T.). Offstage, he enjoys fashion design and garment construction with a concentration on tailoring. He also spends his time exploring the intersection of creativity and science through baking. He would like to thank Theatre Jacksonville for another fantastic privilege to perform with them and both directors Curtis and Julian for the amazing opportunity they've provided. He'd also like to thank his fellow cast mates (a tenured company of musically skilled and talented artists) for such a memorable experience.

JON WOODBINE is thrilled to be doing his second Theatre Jacksonville show. A Jacksonville native with a passion for singing, composition, acting, and education. Graduated from UNF with a BA in Music Education, Jon works as an elementary music teacher where he directs multiple ensembles, and he also sings with the Voices of Jacksonville. He would like to thank his family, friends, and teachers for their love and support throughout his journey as a musician.

**Our Deepest
Gratitude**
to all our supporters!
\$250-\$999 cont.

Davarian Rousseau

Katharine Roth

Austin Sherman

Linda & Michael
Smalline

Dianna Smith

Jo Swallow

Jean Tait

Ann Tiefenthaler

Megan Weinstein

Bill White

Nancy & Robert Wiley

Vicki & Ed Zoller

**Theatre
Jacksonville**
is a member of

American
Association of
Community Theatre

Cultural Council of
Greater Jacksonville

San Marco
Preservation Society

San Marco Merchants
Association

Nonprofit Center of
Northeast Florida

League of Historic
American Theatres

- Page 8 -

CREATIVE TEAM BIOS

JULIAN BRYSON (MUSIC DIRECTOR) is Director of Choral Activities at Radford University (VA), where he directs multiple choirs and teaches courses in conducting, music education, and musical theatre. He earned a doctoral degree in Choral Conducting from the University of Kentucky and has served as musical director for a variety of high school and community shows ranging from *Urinetown* and *The 25th Annual Putnam County Spelling Bee* to *Carmen*, *The Mikado*, and *Oliver*. A commissioned composer and arranger, Julian holds degrees in conducting and composition from the University of Tennessee. His works have earned international performances and recognition from the Yale Glee Club, American Choral Directors Association, The American Prize, and the Florida Vocal Association. His works are published via EC Schirmer, MusicSpoke, and www.julianbryson.com.

CURTIS J. WILLIAMS (DIRECTOR) spent his childhood in musical theatre but was soon taken in by the world of ballet. From 2000 to 2008, he worked as a company artist/resident choreographer with The Florida Ballet and attended the University of North Florida and American University during the first years of his professional career. During that time, he also served as a permanent guest artist and choreographer with Virginia Ballet Theatre, Sierra Nevada Ballet, Los Angeles Ballet, Dayton Contemporary Ballet, and various dance galas across the U.S. After retiring from the world of classical performance, Mr. Williams first returned to musical theatre as a rehearsal director of works from the Bob Fosse repertoire. Since then, he has directed, choreographed and/or costumed productions of *Ragtime*, *Sister Act*, *Thoroughly Modern Millie*, *Mamma Mia!*, *The Drowsy Chaperone*, *Hot Mikado*, *Nine to Five: The Musical*, *Schoolhouse Rock Live!*, *Les Misérables*, *Always A Bridesmaid*, *Hairspray*, *The Last Night of Ballyhoo*, *Love Goes To Press*, *The Laramie Project* and *The Explorer's Club*. An avid hat maker, his millinery skills can be seen in shows around the southeast.

SQUIRREL PITTS (STAGE MANAGER) wants to thank Theatre Jacksonville for giving them a place to get started on or at least near the stage. They have stage managed *SHOUT*, *The Boys Next Door*, and *Dear Jack, Dear Louise* here in San Marco. When they aren't wrangling actors, Squirrel enjoys camping, reading, and people-watching.

JANETTE HORN (PROJECTIONS) is a first timer working backstage on a production and she's excited to continue working with Theatre Jacksonville in the future. Outside of theatre and her work as an analyst, she enjoys cooking, reading, photography, architecture, and exploring new places locally and abroad.

SARA GREEN (SOUND) is happy to be back at Theatre Jacksonville and thankful she gets to end the exchange year doing one last show with her 10th exchange student. She has averaged 2 shows annually since 2004, with notable favorites: *Pajama Game*, onstage as Gladys and *Beauty and the Beast*, as the Director.

TYMOFII “TIMA” SMIRNOV (ASSISTANT STAGE MANAGER) is in Florida on exchange from the Ukraine. He wants to thank Theatre Jacksonville and his host mom for making this one last theatre experience possible in his exchange year.

TECHNICAL PRODUCTION TEAM

Director	Curtis J. Williams
Music Director	Julian Bryson
Production Manager	Michelle Leigh
Costume Design	Classic Costumes
Light Design	Triple O Productions
Sound Design/Operator	Brent Mulberry
Stage Manager	Squirrel Pitts
Assistant Stage Manager	Tima Smirnov
Lighting Board Operator	Aspen Krill
Projection Operator	Janette Horn
Music Sound Board Operator	Sara Green
Wardrobe	Lourdes “Lou” Acosta



**Minuteman
Press** Downtown
Jacksonville
WE DESIGN, PRINT & PROMOTE...YOU!



Theatre Jacksonville

2032 San Marco Blvd.
Jacksonville, FL 32207

Officers

Demetrius Jenkins
President

Leah Walker Goryl
Vice President

Ann Tiefenthaler
Treasurer

Jennifer Leach
Secretary

Directors

Regina Edwards

Greg Hewitt

Sandy Myers

Katharine Roth

Mitchell Skowbo

Austin Sherman

Jean Tait

Megan Weinstein

Staff

Sarah Boone
Executive Director

Michelle Leigh
General Manager

Ron Shreve
Educational Director

Katie Allen
Katie Cress
Squirrel Pitts
Box Office Support

Additional Supporters: \$50-\$249

Anonymous	Linda & Thomas Culverwell	Shannon O'Leary
Roz & Mark Abramson	Linda Deshauteurs	Anne & John Petersen
Mahesh Adhyaru	Sherrill Dewberry	Eileen Phelps
Amy Bandalos	Lynda Dupes	Larry Phillips
Barbara & John Barker	Linda & Matt Godek	Carole & Al Poindexter
Laura Bearl	Sherra & Charles Grabill	Sudhir Prabhu
Helen & Greg Beedy	Diane Hale	Perry Reynolds
Judy & Larry Brazile	Alice & Charles Harper	Valerie Robinson
Suzanne & Leigh Broward	Alison Henderson	Jay Rolfe
Elizabeth Brown	Jean Colandrea & Jeff Hoek	Alice Schill
Arden Brugger	Judith Israel	Helen Morse & Fritz Skeen
Heather Campbell	Shannon & Mike Italia	Ann Stine-Sapp
Jeanne Maron & Howard Caplan	Rebecca & Jay Karp	Claudette Thornell
Wendy Chambers	Gale & Timothy Keeley	Paula & Eric Wester
Lee Ann & Jeff Clements	Teresa & Daniel Lahey	Kathleen Wood
Joan Collins	Wayne Letizia	
Deborah Crumb	Marcia Mederos	
Maureen Cullum	Patricia Mierse	

*Donations listed on this and other pages reflect the period
May 31, 2025-June 1, 2026.*

SEASON 2026-2027 107



To order your ticket plan online, **VISIT OUR SEASON PAGE TODAY!**

The Classic in San Marco:
(included for All-Access Members)

The Lion in Winter

by James Goldman

September 19, 20*, 24, 25, 26, 27,* October 1, 2, 3*, 4*, 2026
Winner! Three 2023 Drama Desk Awards

"A work of intelligence, astringent wit, and much theatrical skill."
- *The New York Times*

The Mainstage Season:

(included for All-Access Members & Subscribers)

Come From Away

Book, Music and Lyrics by Irene Sankoff and David Hein

November 7, 8*, 12, 13, 14, 15*, 19, 20, 21*, 22*, 2026

2017 Drama Desk Award for Outstanding Musical
2019 Olivier Award for Best New Musical

"A flight from our troubles into total joy." - *The Times*

The 39 Steps

Adapted by Patrick Barlow

From the novel by John Buchan

January 16, 17*, 21, 22, 23, 24*, 28, 29, 30*, 31*, 2027

"Ingenious! A dizzy delight!"

- *Daily News*

Crimes of the Heart

By Beth Henley

February 27, 28*, March 4, 5, 6, 7*, 11, 12, 13*, 14*, 2027

Winner of the Pulitzer Prize

"overflows with infectious high spirits."

- *The New York Times*

Theatre People, or The Angel Next Door

By Paul Slade Smith

April 17, 18*, 22, 23, 24, 25*, 29, 30, May 1*, 2*, 2027

"a glittering, effervescent hit romantic comedy"

- *Broadway World*

Nunsense

Book, Music and Lyrics by Dan Goggin

June 12, 13*, 17, 18, 19, 20*, 24, 25, 26*, 27*, 2027

Winner! Outer Critics Circle Awards for

Best Book, Music and Off-Broadway Musical

"A hail of fun and frolic! Wacky and outrageous"

- *The New York Times*

All evening performances are at 7:30pm. *Matinee performances are at 2pm. Lobby box office opens 30 minutes prior to showtime.

ALL-ACCESS MEMBERSHIPS

Receive one ticket for each Mainstage offering, plus *The Classic in San Marco* and all Extras.

Sr./Military, \$130[†]
(60+ or military ID)

Adult, \$170[†]
(18-59 years old)

Sr./Military, \$150[†]
(60+ or military ID)

Additional tickets, \$22, as available.

107TH SEASON SUBSCRIPTIONS

Receive one ticket for each

Mainstage offering. (The *Classic in San Marco* and Extras not included.)

Adult, \$140[†]
(18-59 years old)

Sr./Military, \$120[†]
(60+ or military ID)

Additional tickets, \$25[†], as available.

A LA CARTE

Offered on a show-by-show basis, \$31[†], only as seats are available.

[†]Online purchases subject to service fee.

Protecting Careers is our Business.

Delegal & Poindexter provides highly specialized legal services to employees facing employment agreement disputes, professional license discipline, public and private employment litigation, and others.

Delegal
Poindexter &
Underkofler P.A.

Specialists in Labor & Employment Law

424 E. Monroe St., Jacksonville, FL 32202
(904) 633-5000 | protectingcareers.com